



## 1968-1974 Nova Rear Torque Arm

### Install Sheet

1-855-693-1259

[www.totalcostinvolved.com](http://www.totalcostinvolved.com)

**CHECK ALL PARTS INCLUDED IN THIS KIT TO THE PARTS LIST BEFORE INSTALLATION OF THE KIT.  
IF ANY PIECES ARE MISSING, PLEASE CONTACT: TOTAL COST INVOLVED 1-855-693-1259**



67 [429-4202-00] OR 68-69 [429-4202-00]		REAR BRACKETS		BARS		Shocks	
Includes:		Includes:		Includes:		Includes:	
1	REAR C/O CROSSMEMBER	1	DRV SIDE BKT	2	18 1/2 * 1 1/4 Performance Bars w/ bushings	2	All-American C/O Shocks
1	BOLT-ON PANARD BRACKET	1	PAS SIDE BKT	2		5/8-18 * 4 1/2" Bolts	
2	RE-ENFORCEMENT PLATES	1	DRV SIDE TOP PLT	2	3/4 Stainless Adjustors w/ jams & bushings	2	5/8-18 * 5 1/2" Bolts
2	SHOCK BLOCK OFF PLATES	1	PAS SIDE TOP PLT	2		Upper 5/8" Spacer	
1	WELD-ON PANARD BRACKET	32	5/16-24 * 1 1/4 SBCH			2	Lower 2 3/8" Spacer
4	5/16-24 * 1 1/4 SBCH note (67 will have 8)	32	5/16-24 NYLOX	1	Panard Bar Reg = 39" Pro = 37"	<b>Axle Brackets</b>	
4	5/16-24 NUT NYLOX note (67 will have 8)	32	1/4 USS WASHERS	2		Torque Arm Axle Brackets	
4	5/16 FLAT WASHERS note (67 will have 8)	4	3/8-16 * 1" BOLTS	4	5/8-18*2 3/4 SBCH	<b>Torque Arm Assembly</b>	
4	5/16 -18 * 3/4 SBCH	2	3/8-16 * 1 1/4" SHCS	4	5/8-18 1/2 NYLOX	1	Main Torque Arm
4	5/16 LOCK WASHERS	1	3/8 Drill Guide	1	5/8 RH Heim w/jam	1	Slider Assembly
4	3/8 -24 * 3" HEX G8	4	3/8 -16 * 3 1/2" HEX G8 3/8-24 * 3" G8 (PRO)	1	5/8 LH Heim w/jam	1	TA Cross member w/ Drive Shaft loop
4	3/8 24 NUT NYLOX	4	3/8-16 NUT, PLAIN 3/8-24 1/2 NYLOX (PRO)	2	1/2-20 * 2" G8	2	Pinion Support Tubes 13 3/8 x 3/4 inch
8	3/8 FLAT WASHERS	6	3/8 LOCK WASHERS	2	1/2-20 NYLOX	2	1/2 RH Heim w/jam
		8	3/8 FLAT WASHERS	4	1/2 Flat Washers	2	1/2 LH Heim w/jam

**Torque Arm Assembly Continued**

1	Torque Tab Location Tool	1	Reg Hsg Torque Tab Kit	1	Top pinion support spacer 3/4 x 5.2"		
1	Torque Rear Location Tool	1	F9 Hsg Torque Tab Kit	2	Lower pinion support spacers 1 1/4 x 1 1/2 "		
2	1/2 -20 Full Nylox	4	1/2 Flat Washers	2	1/2 -20 x 8" G8 Pinion support T & B		

**SUBFRAME CONNECTORS**

**Options**

Included with Torque Arm		SHOCKS		Bar Kit		SWAY BAR KIT	
TCI CONV [429-4622-00]		Chrome All-American		Chrome or Polished Bar Kit (Link & Panard)		3/4" Sway Bar Kit Plain or Chrome	
TCI COUP [429-4621-00]		Billet Adjustable C/O Plain					
STK CONV [429-4624-00]		Billet Adjustable C/O Polished					
STK CONV [429-4623-00]							

Complete Rear End Assembly w/ Brakes

**The car needs to be securely positioned on tall jack stands or preferably a hoist to facilitate removal of the old components. Temporarily remove the rear seat and the carpet in the area that the floor will be drilled through.**

**The 2/4 link bracket is installed first. Any high spots on the floor pan will have to be ground flush so the bracket will set flat against the body when bolted up to the original front leaf spring hanger holes.**

**Position the brackets with the curved end rearward going up the floor pan and the channel aligned over the frame rail. Install the 2 hex head 3/8 x 1 inch bolts on the front and frame channel using flat washers and lock washers. Leave bolts partial loose to facilitate installing the 3/8 x 16 x 1 1/4 socket head bolt with lock washer on the outside hole up inside of the bracket. This can be a little tricky as the nut is on a clip that wants to move around. I ground a slight point on the bolt to help center the inside nut. With the socket headed bolt tight finish tightening the rest of the bolts.**

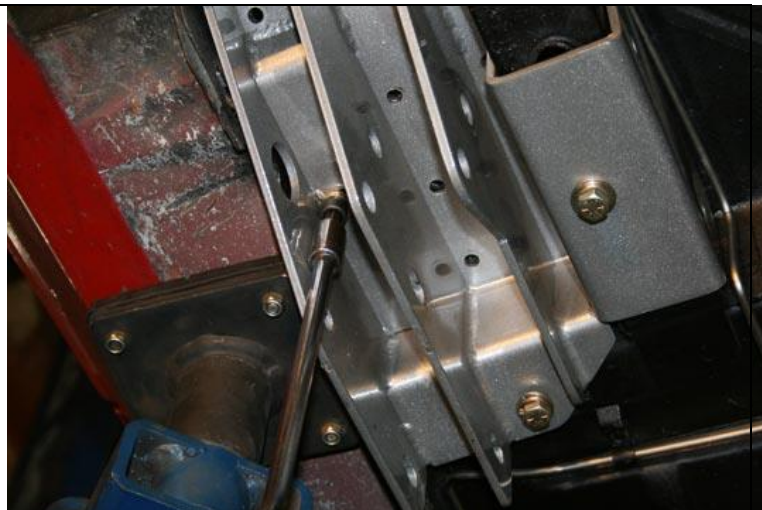
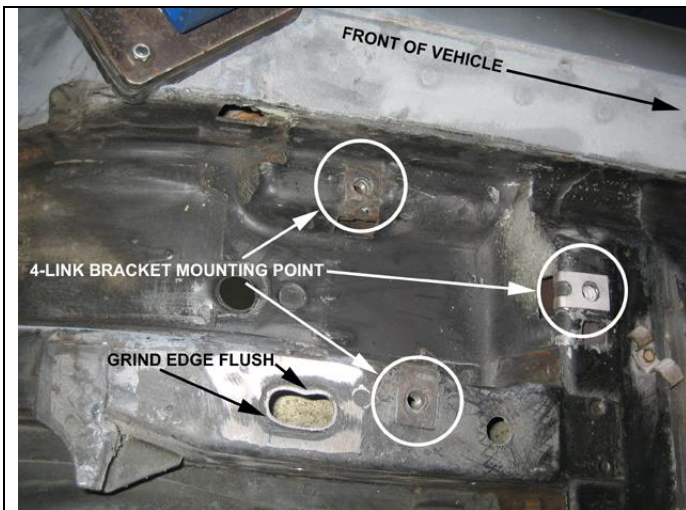

The flange on the outer rail will have to have a radius for clearance to install the link bolt if the top hole is to be used. When the link bar is installed in the top hole the bar will be angling down toward the rear axle bracket and as the car rolls on that side when making a turn the front of the bar will move down pushing the rear axle rearward inducing rear roll steer which is desirable in cornering. With the bar in the lower bracket hole roll steer is eliminated but forward bite is increased. The bracket shown is for a two inch inset mini-tub application.



Next using the 5/16 inch bracket holes as a guide, drill one 5/16 hole through the floor pan and install one of the 5/16 x 1 1/4 x 24 button head bolts and install nut on inside and tighten. This will keep the bracket from moving around while drilling and all holes will line up when finished. Finish drilling remainder of the holes using a long shank 5/16 inch drill bit.



Align the appropriate curved re-enforcing plate on the inside of the car over the drilled bolt holes and have a second person push the 5/16 button headed bolts through the bracket underneath. Install the washers and the 5/16 Nylock nuts and tighten.

**Note:** You may have to grind a flat on the side of the bolt head because a few of the holes are close to the inside of the bracket.





Using a 3/8 inch drill bit and using the 3/8 inch holes in the channel bracket, drill the inside holes through the frame rail. Then using the furnished drill guide, align the drill bit in the guide with the drill bit in the previously drilled hole and clamp the guide as pictured. This will facilitate in keeping the drill bit in line with the outside holes in the bracket.

Install the four 3/8 x 16 x 3 1/2 inch bolts washers and Nylock nuts. Note: On mini-tub applications use 3 inch long bolts with 1/2 nuts. With the link bar bolt installed the clearance is tight.



Install the 1 3/4 neoprene end caps in the sub-frame connectors. If using a TCI front clip, position the connector tube as shown and install the front 1/2 x 20 x 3 1/2 inch bolts with the bolt heads on the inside of the clip tube and the nuts go on the curved receiver side of the connector tube. The rear bolts take washers on both sides and go through the bracket with the nuts on the inside. Bolting on the connectors for a stock clip will require drilling six 3/8 holes using a furnish template. Comes with an inside reinforcing plate and hardware.

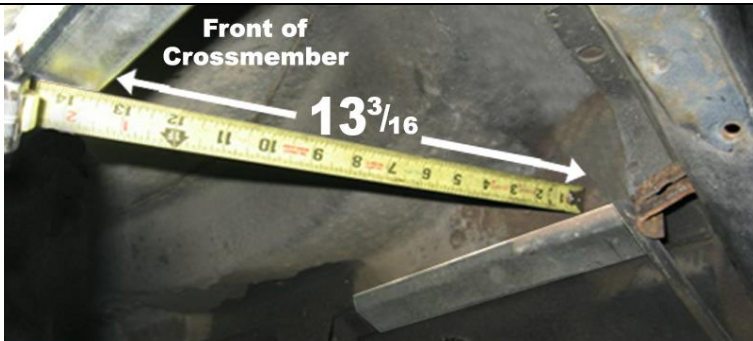

The coil-over cross-member is next. Remove any hanger brackets that will interfere.

On the 1967 Camaro, the cross-member is installed up flush with the rear frame rails and measured 13 3/16 inches from the flat vertical body panel to the front edge of the cross-member. The ends of the cross-member are angled in at the front.



The 1968-69 Camaro coil-over cross-member is located by the two existing 3/8 x 16 threaded holes in the frame rail. Using the four 3/8 x 16 x 1 inch bolts, fasten the front flange of the cross-member to the frame and push the saddle of the cross-member flush before tightening.



With the channel bracket pressed flush against the frame rail, use a 3/8 drill bit and drill the two outside holes in each frame rail using the holes in the channel bracket as a guide.

Using the drill bushing guide over the previously drilled hole, clamped the guide to the bracket, drill horizontally through the other side of the frame and through the hole in the bracket.

Finish by installing the four 3/8 x 16 x 3 inch bolts, washers and Nylock nuts and tighten.





Using the 5/16 inch holes on the flange of the channel bracket as a guide, use a long shank 5/16 drill bit and drill the 4 holes (2 on 68-69) through the floor of the trunk.



Install the 4 hole re-enforcing plate (2 hole on 68-69) over the holes and install the 5/16 x 24 x 1¼ inch button head bolts and washers through the plate, trunk sheet metal and through the cross-member channel bracket.



Install the 5/16 Nylock nuts and tighten.

Top photo: 1967 Camaro

Bottom photo 1968-69 Camaro



The Torque Arm cross-member is installed with the driveshaft loop facing rearward and the end flanges of the cross-member under the brackets on the sub-frame connectors. Using the 3/8 x 16 x 1 inch bolts and washers, bolt the cross-member to the sub-frame brackets and install the 3/8 Nylock nuts and washers. Double check to make sure that the driveshaft loop is centered in the driveshaft tunnel before final tightening.



When installing the optional ¾ inch rear sway bar, first slide the lock rings on. Next the split urethane bushing with flange facing lock ring. Next the brackets with the flange facing rearward and the sway bar forward. Leave lock rings loose to facilitate install. Install the four 3/8 x 2½ bolts, washers and Nylock nuts. Adjust sway bar location after rear axle is installed. Note: We mounted the fuel filter and pump to the cross-member.

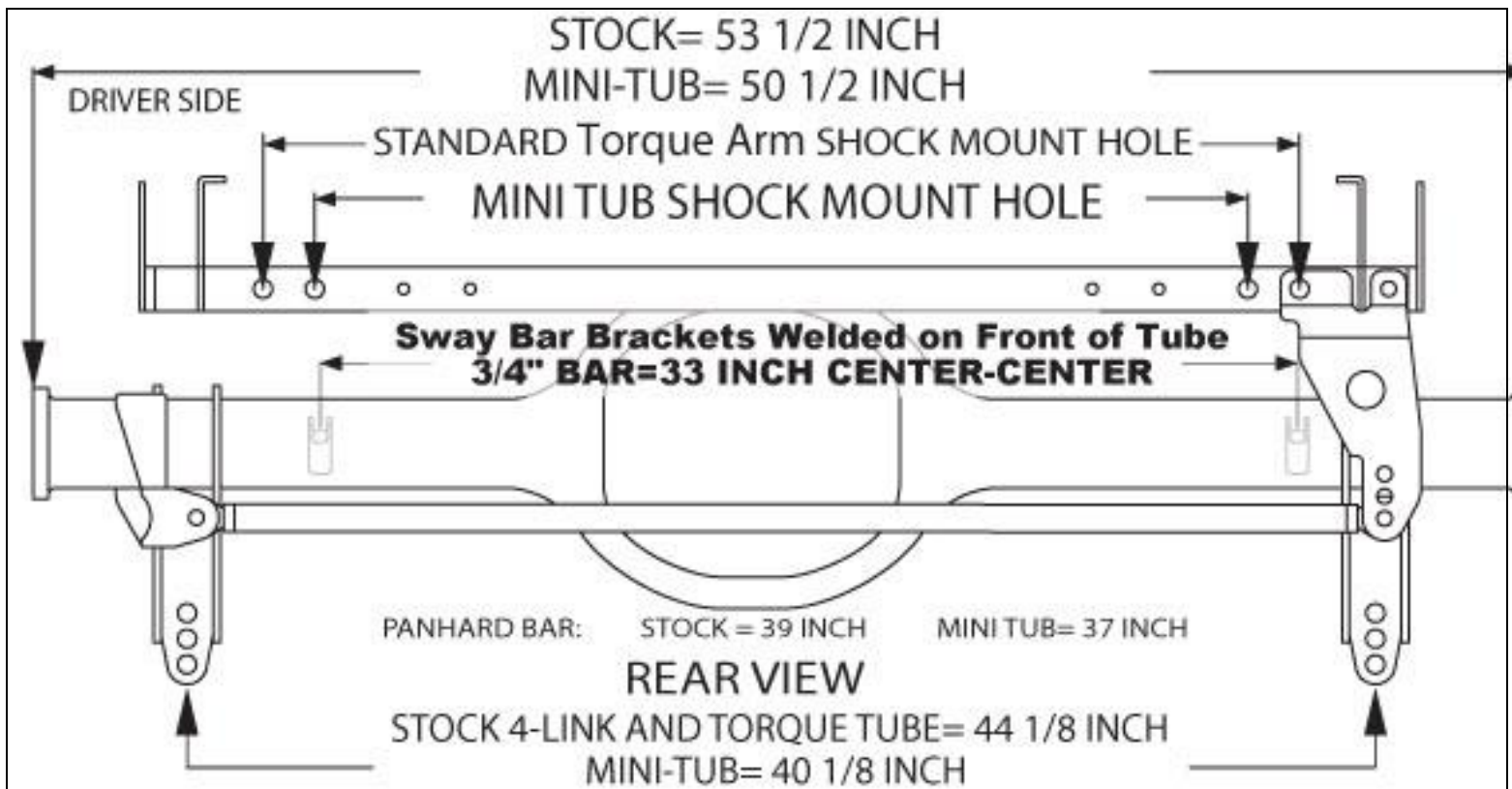

**1967-69 Camaro**

Housing width stock-----53½ inches: Axle flange to axle flange 58 ½ inches  
 Housing width mini-tub---50 ½ inches: Axle flange to axle flange 55½ inches

**1968-72 Nova**

Housing width stock-----52 ½ inches; Axle flange to axle flange 57½ inches  
 Housing width mini-tub--50 ½ inches: Axle flange to axle flange 55 ½ inches



The axle brackets are designed to slide over a 3 inch axle tube before the bearing flange housings are installed. If the bearing ends are already on the axle bracket 3 inch ribs can be cut 90 degrees to the flat shock mounting face and re-attached after the bracket is tacked on. The brackets are positioned 44 1/8 centers for stock width and 40 1/8 for the 2 inch mini-tub.

The flat rear surface of the axle bracket is parallel with the front mounting surface of the 3<sup>rd</sup> member.

The panhard bar bracket is installed onto the back of the driver's side axle bracket with the channel facing out and the inner curved radius inside the outer axle bracket rib up against the 3 in axle tube rotated down against the rear face of the axle bracket.





The torque arm tabs are welded on by using the supplied fixture tool. Bolt fixture to the lowest 2 third member bolts flat against the housing flange. Bolt on the two supplied tabs using the  $\frac{1}{2}$  by  $3\frac{1}{2}$  inch bolt and with the longer tab to the passenger side of the housing. Bottom of tabs may need sanding to fit. Weld outside and wrap welds also to the inside.



Finish welding the axle brackets and the panard bar bracket as pictured. If an optional sway bar is being used the sway bar brackets are located on the front of the axle tubes at axle centerline on 33 inch centers.

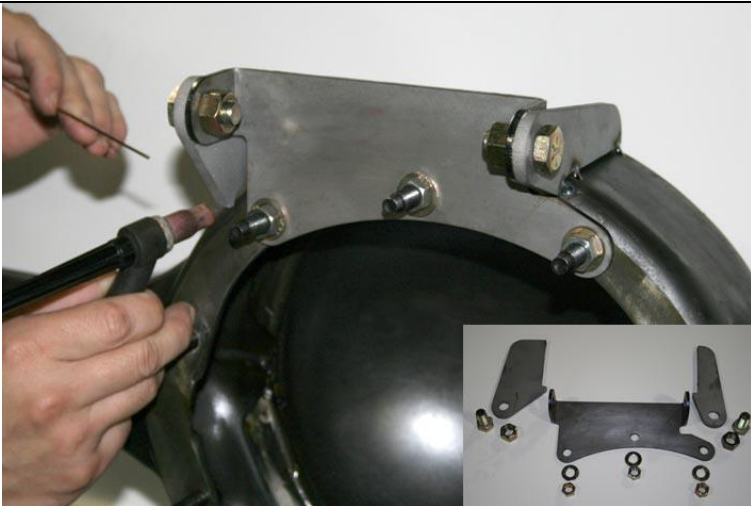

The pinion support brackets are installed next. Using the furnished fixture tool, using the three  $\frac{3}{8}$  by 24 nuts, bolt the fixture onto the top three studs of the third member housing with the locating tabs facing forward. Bolt the  $\frac{1}{4}$  inch laser cut brackets to the outside of the fixture tool using the two  $\frac{1}{2}$  inch bolts with the wider bracket on the passenger side and the shorter bracket on the driver side. Note; Some fitting may be required to get the bracket flush with the top of the third member. The distance between the 2 brackets should be 6.45 inches after welding. Because of the distortion from welding the housing will need to be straightened at this time.

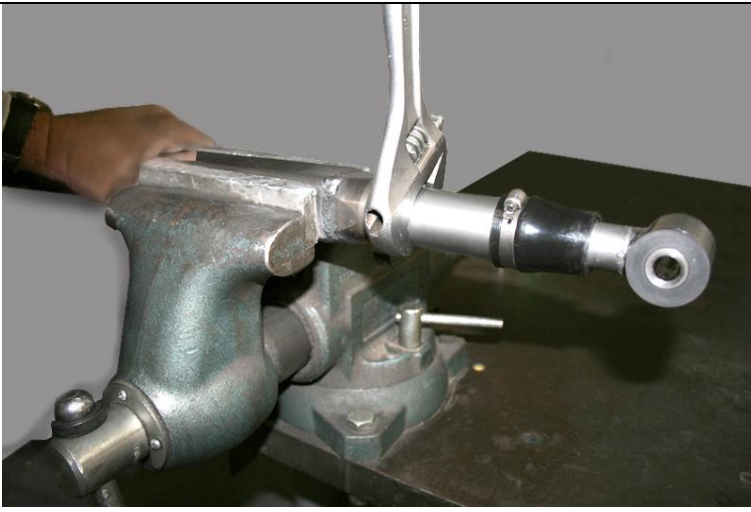

**The Torque Arm is shipped with the slider assembly separate to facilitate packaging. The slider has pre-assembled with Teflon bushings and has been installed in the Torque Arm to check for proper fit. We use anti-seize on the threads to prevent galling. When painting or powder coating the assembly, tape the threads on the slider and plug the hole in the Torque Arm tube.**

**Install the slider into the Torque Arm using anti-seize and be careful not to cross thread and tighten. I used a vise and a 12 inch crescent wrench to make sure it was tight.**

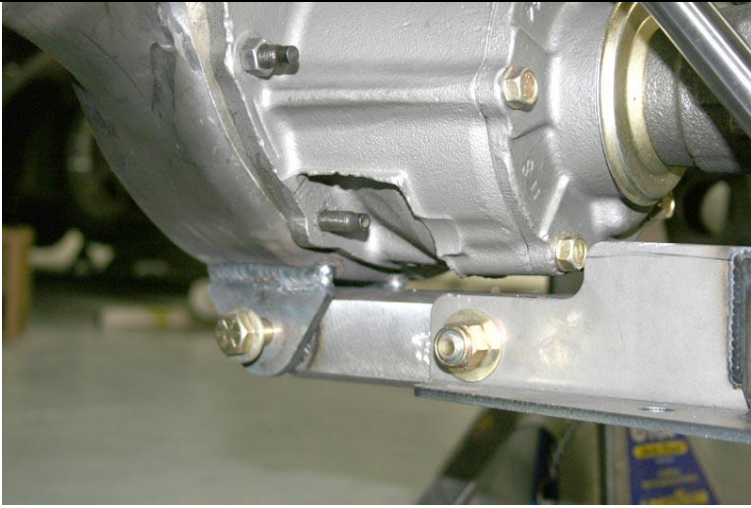

**Install the rear of the Torque Arm to the tabs on the bottom of the rear end housing using a 1/2 inch by 3 1/2 inch bolt, washers and nut. Lightly tighten.**





The pinion support tubes have left and right hand rod ends to facilitate pinion angle adjustment. Adjust the tubes to approximately the same length with an equal amount of threads showing on each rod end. Install the tubes with the right hand rod ends on the inside of the top brackets using the 1/2 by 8 inch bolt, washers, 5.2 inch spacer in between rod ends and Nylock nut.

The left hand end of the tube is installed on the inside of the Torque Arm bracket with the spacer between the rod end and the Torque Arm tube. Install the 1/2 by 8 inch bolt through the bracket, rod ends, tube and spacers. Install Nylock nut and tighten. Now, tighten the nut on the bottom of the housing.

**Note:** On our 68 Camaro with 2 1/2 inch exhaust and Flowmaster mufflers, I had to unbolt the lower end of one of the pinion support tubes to allow enough clearance to get the 3 1/2 inch drive shaft installed then reconnect the pinion tube. To adjust the pinion angle after installation is complete; the tubes can be rotated simultaneous clockwise to raise the pinion or counter-clockwise to lower the pinion. I adjusted the pinion one degree down from the drive shaft. Tighten lock nuts top and bottom.



The slider shaft travels in and out very little but still needs to be positioned in the slots 6 1/4 inches from the back of the wrench flats on the housing to the center of the sleeve with the bushing in it. This adjustment allows the slider shaft to be in the middle of its travel. Tighten the Nylock nut.



**The slider is installed and centered. The Torque Arm cross-member has exhaust cut out relief's to allow the exhaust pipes to be tucked up higher for more ground clearance.**

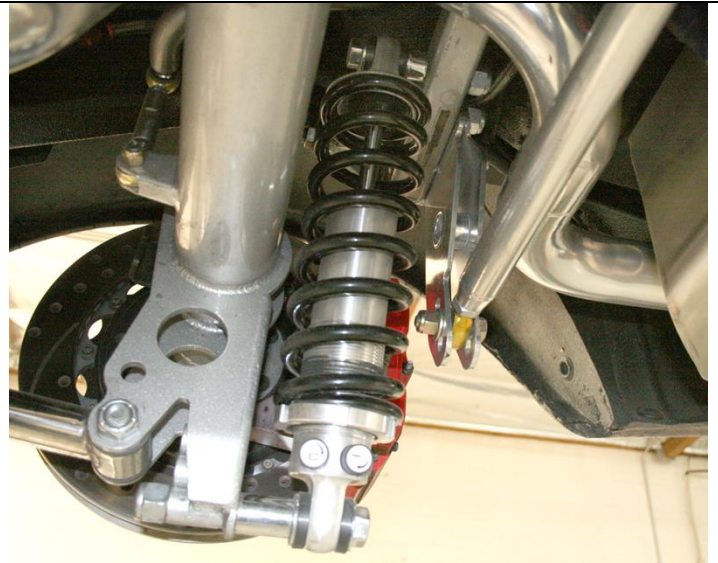

**The photo on the left shows the panard bar attached to the axle housing bracket using  $\frac{1}{2}$  x 20 x 2 inch bolt, washers and Nylock nut. The process is repeated on the right side on the panard bar bracket that is bolted to the coil-over cross-member. The three hole adjustment gives the choice of raising or lowering the rear roll center.**

**Finish the project by installing the shock hole block off plates using the four  $\frac{5}{16}$  x 18 x  $\frac{3}{4}$  button head bolts.**



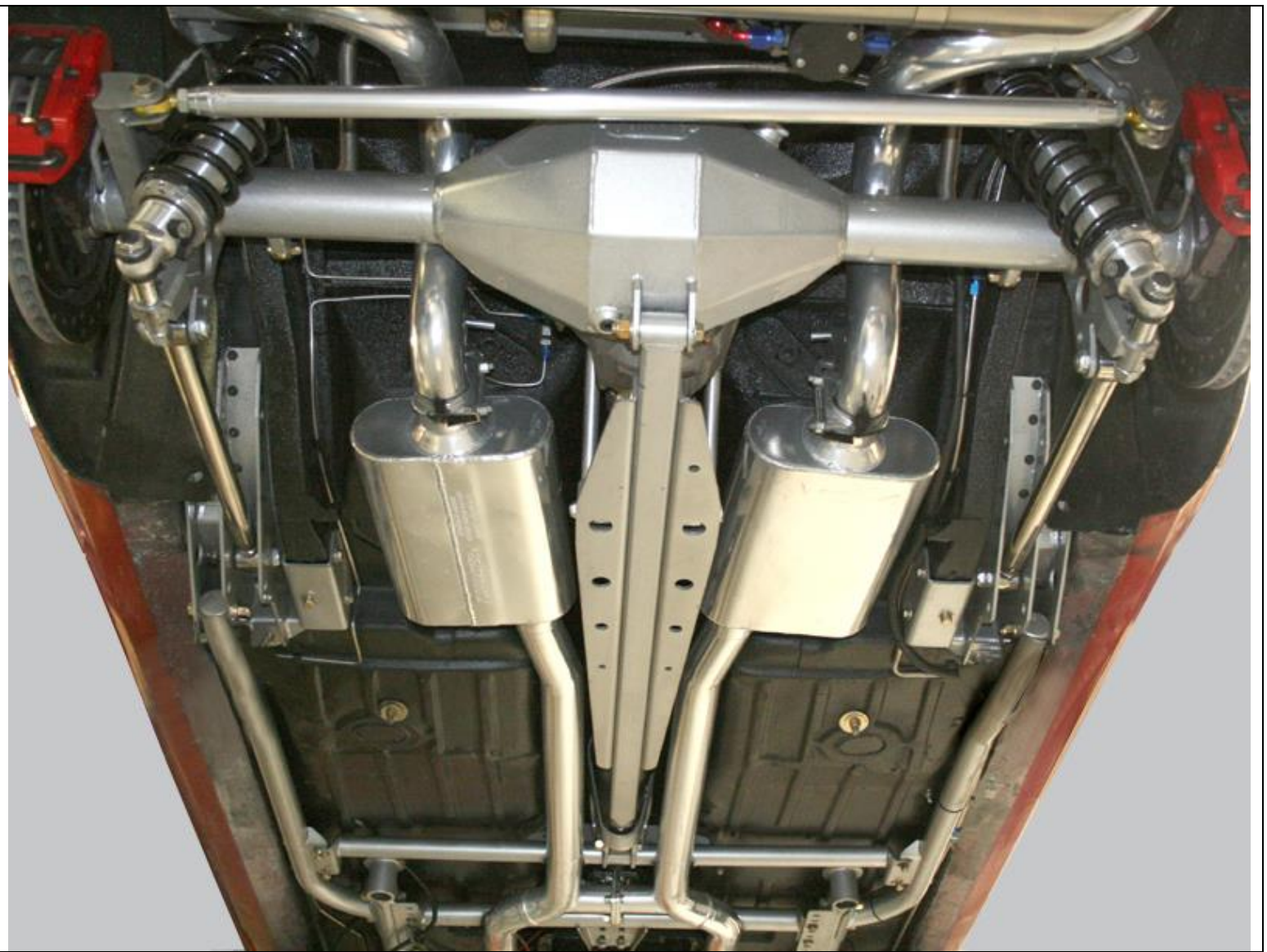

**The Torque Arm rear suspension completely installed. The TCI Camaro uses 2½ inch exhaust system and Flowmaster mufflers. Everything is tucked up close and tight so installing the driveshaft should be done before installing exhaust system and leaving one of the pinion support tubes off until the driveshaft is installed.**